



www.corp-branding.de

TECHPACK PRESET



HOW IT WORKS

All custom products under the PRODUCTION SERVICES segment are made-to-order and only produced upon request. Please fill in the tech pack with your data so it gives a detailed description of your item. Should the tech pack not cover certain aspects of what you want, feel free to add comments for us to review its feasibility. Include any drawings of additional documents in the annex.

Email your completed tech pack to info@corp-branding.com. We will arrange a call if needed.

You have the option to order a sample, read infos here

<https://corp-branding.de/pages/sample>.

Approve the final, production-ready tech pack and confirm your order. Production will commence once we have received your payment. After the products pass our quality check, we will send you the tracking number.



GUIDANCE

PLEASE READ CAREFULLY AND GO STEP BY STEP!

1 MEASUREMENTS:

Custom fit means that you can fully customize and adapt the measurements of the standard product to your wishes and create a custom cutting pattern. The custom fit program offers the ultimate customization possibilities to create truly unique and outstanding silhouettes. If you want to customize more than just the dimensions (e.g. delete or add pockets, combination of fabrics, ...), please note it below and include specific drawings with according measurements. If you already have cutting patterns for your piece, please attach them.

2 SIZE DISTRIBUTION:

Minimum order is 100 pieces in total. For custom Pantone colors, the minimum order is 250 Pieces.

3 FABRIC:

Please provide the PANTONE TCX code for your preferred colorway. Additionally, you can choose from a variety of dyeing techniques. Please note that the minimum order quantity (MOQ) will increase. (The weight has a tolerance of 10% from the specified weight in grams per square meter (GSM).)

4 PACKAGING:

We can offer you packaging, however you need.



GARMENT:

SEASON:

DATE OF ISSUANCE:

STYLE CODE:

LINE:

DELIVERY DATE:

DESIGNER:

SIZE:

SUPPLIER:

PRODUCT OVERVIEW

(PLACE ALL PRODUCTS HERE)



GARMENT:
STYLE CODE:
DESIGNER:

SEASON:
LINE:
SIZE:

DATE OF ISSUANCE:
DELIVERY DATE:
SUPPLIER:

(PLACE DESIGN HERE)

HEIGHT

_____ **CM**

WIDTH _____ **CM**

USED TECHNIQUE:

- SCREEN PRINT**
- PUFF PRINT**
- RUBBER PRINT**
- EMBROIDERY**
- OTHER:**

COLOR REFERENCE
(DUPLICATE IF YOU HAVE MORE COLORS)

DESIGN DESCRIPTION FRONT



GARMENT:
STYLE CODE:
DESIGNER:

SEASON:
LINE:
SIZE:

DATE OF ISSUANCE:
DELIVERY DATE:
SUPPLIER:

(PLACE DESIGN HERE)

HEIGHT

_____ **CM**

WIDTH _____ **CM**

USED TECHNIQUE:

- SCREEN PRINT**
- PUFF PRINT**
- RUBBER PRINT**
- EMBROIDERY**
- OTHER:**

COLOR REFERENCE
(DUPLICATE IF YOU HAVE MORE COLORS)

DESIGN DESCRIPTION BACK

GARMENT:
STYLE CODE:
DESIGNER:

SEASON:
LINE:
SIZE:

DATE OF ISSUANCE:
DELIVERY DATE:
SUPPLIER:

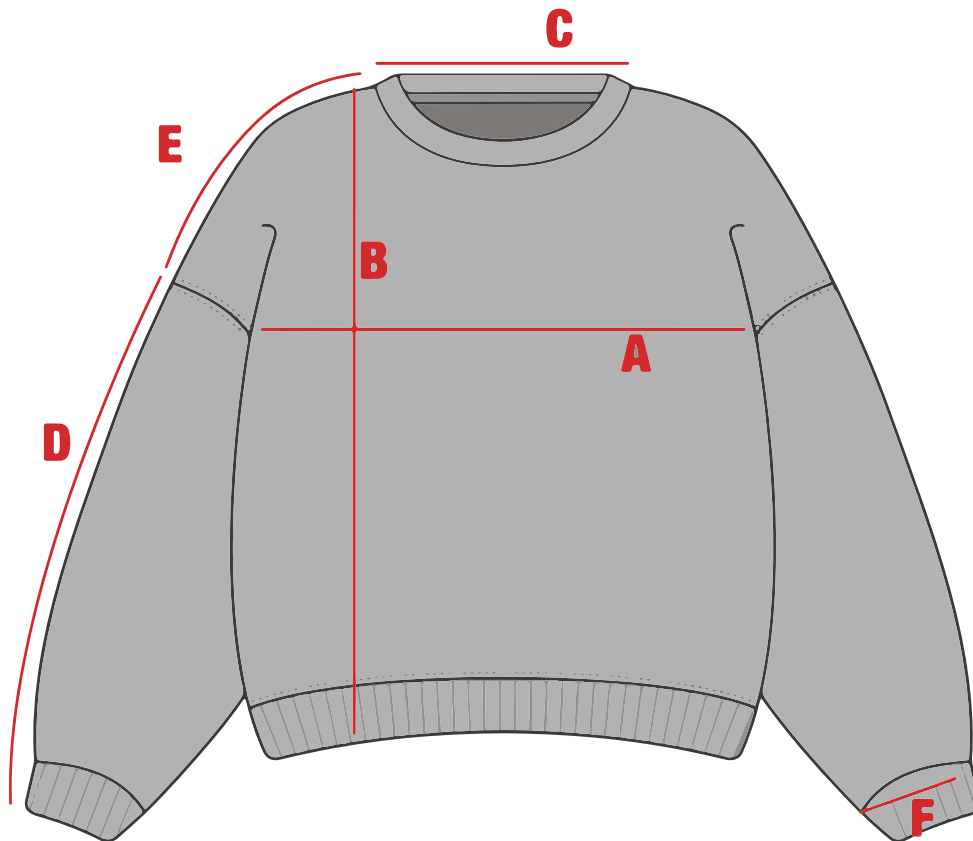

FRONT

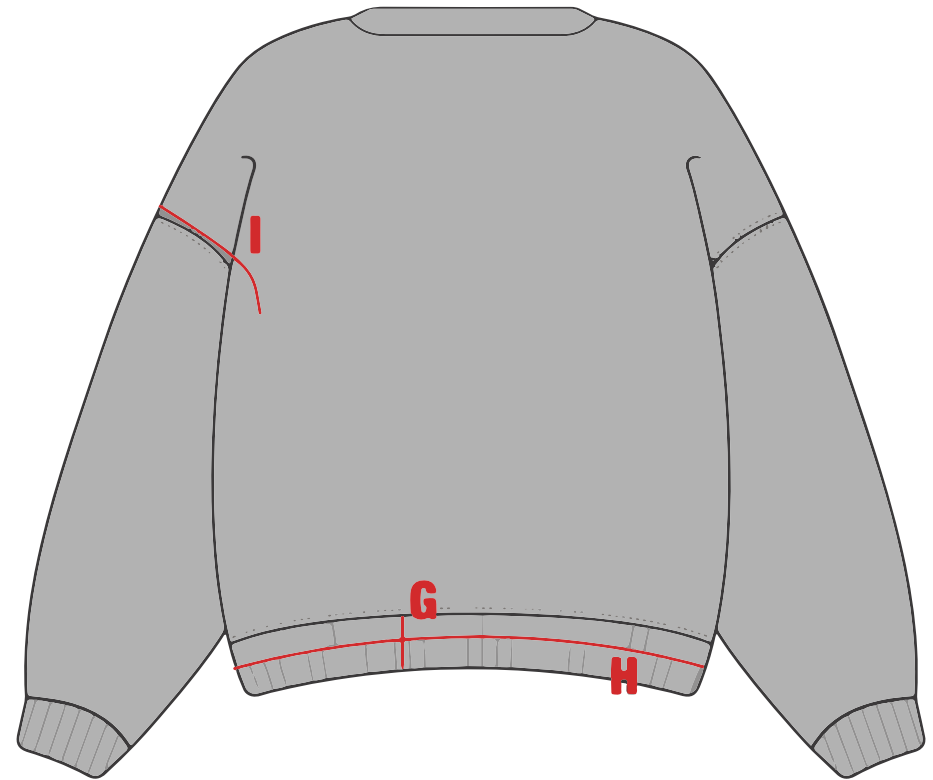

BACK

MEASUREMENTS

WHEN "A/B/C ...": FILL IN MEASUREMENTS IN THE TABLE (NEXT PAGE)



GARMENT:	SEASON:	DATE OF ISSUANCE:
STYLE CODE:	LINE:	DELIVERY DATE:
DESIGNER:	SIZE:	SUPPLIER:

IN CM

OUR BLANK CUTS

	MEASUREMENTS	XS	S	M	L	XL	XXL
A	CHEST WIDTH						
B	TOTAL LENGTH FROM HPS						
C	NECK OPENING						
D	SLEEVE LENGTH						
E	SHOULDER LINE						
F	SLEEVE RIBB WIDTH						
G	RIBB HEIGHT						
H	BOTTOM WIDTH						
I	ARMWHOLE						

SIZE DISTRIBUTION:

SIZE	XS	S	M	L	XL	XXL
BULK						
SAMPLE						

SPECIAL REQUESTS OR COMMENTS REGARDING YOUR FIT?

SIZE CHART

FILL IN THE MEASUREMENTS FROM "MEASUREMENTS" IN THE TABLE



GARMENT:
STYLE CODE:
DESIGNER:

SEASON:
LINE:
SIZE:

DATE OF ISSUANCE:
DELIVERY DATE:
SUPPLIER:

GSM

- 100% COTTON / 320 GSM**
 - 100% COTTON / 380 GSM**
 - 100% COTTON / 450 GSM**
 - 80% COTTON / 380 GSM**
20% POLYESTER
 -
-

COLOR

PANTONE (TCX-CODE):

180 GSM / 220 GSM / 250 GSM

DYE

- WASH EFFECT**
- SOLID (NO WASH)**



GARMENT:
STYLE CODE:
DESIGNER:

SEASON:
LINE:
SIZE:

DATE OF ISSUANCE:
DELIVERY DATE:
SUPPLIER:

HANGTAG

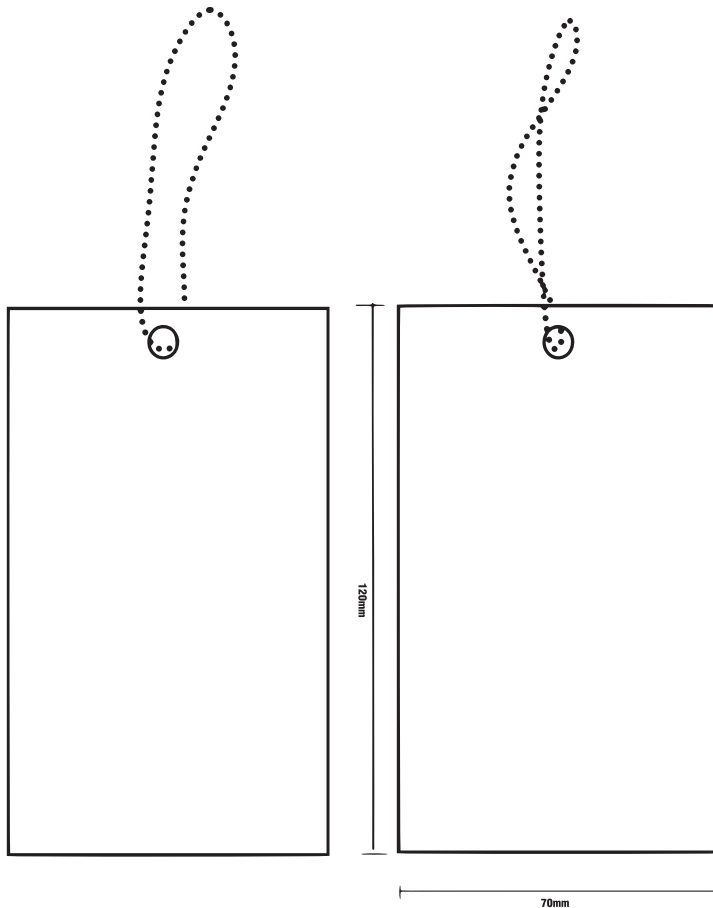

WOVEN FOLD NECK LABEL

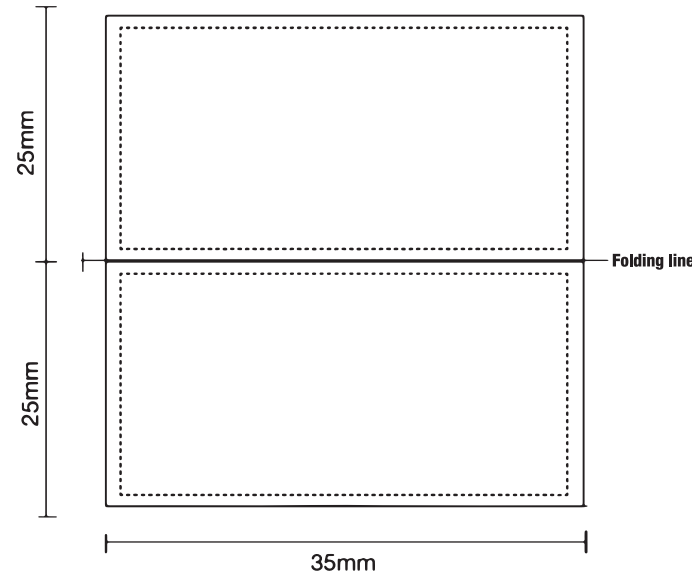

Woven label MATTE WHITE

NECK LABEL

- White
- Other
- Black

CARE LABEL

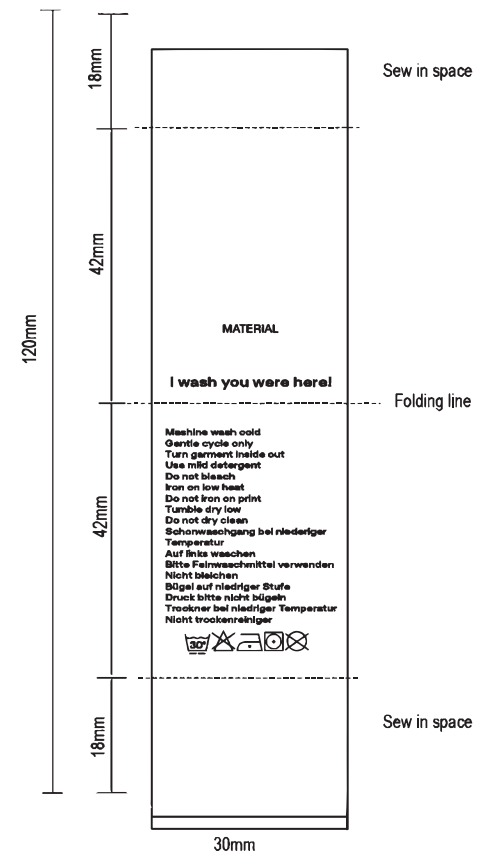

CARE LABEL_TB_Care_Label
120mm x 30mm End Sew In Soft Woven label MATTE WHITE



GARMENT:

SEASON:

DATE OF ISSUANCE:

STYLE CODE:

LINE:

DELIVERY DATE:

DESIGNER:

SIZE:

SUPPLIER:

PERSONAL & CONTACT

FULL NAME: _____

ADDRESS: _____

ZIP-CODE: _____

CITY: _____

COUNTRY: _____

E-MAIL: _____

PHONE: _____

BUSINESS / CUSTOMER

BRAND NAME: _____

CUSTOMER NR: _____

INSTAGRAM: _____

WEBSITE: _____

DATE: _____

CUSTOMER INFORMATIONS

ALL YOUR NECESSARY INFORMATIONS FOR US

THANK YOU FOR CHOOSING



www.corp-branding.de